



Sound Package

Fargo-Moorhead Community Theatre

Sound Designer & Draftsperson: Christian Ekren
Sound Technicians: Eliana R. Michaela D. Liam F.

Director: Lori Bartlett Koenig
Stage Manager: Brenna Lahren
Technical Director: Tanner Lind

Load-In & Tech Rehearsals: November 26 – December 6, 2018
Performance Dates: December 7-9, 13-16, 20-22, 2018





"A Christmas Story"

The Stage at Island Park

Fargo-Moorhead Community Theatre

December, 2018

DIRECTOR:
LORI BARTLETT KOENIG

SOUND DESIGN:
CHRISTIAN EKREN

SOUND TECHNICIANS:
ELIANA R. MICHAELA D. LIAM F.

VOX ONE LINE

DATES:

LOAD-IN & TECH REHEARSALS:
NOVEMBER 26 - DECEMBER 6, 2018

PERFORMANCES:
DECEMBER 7-9, 13-16, 20-22, 2018

REVISION: 2

1ST LOOK:
10/9/2018

FINAL COPY:
1/12/2019

DRAWN BY:
C. EKREN

DATE:
1/12/2019

SCALE:
NO SCALE

PLATE #:

1 of 13

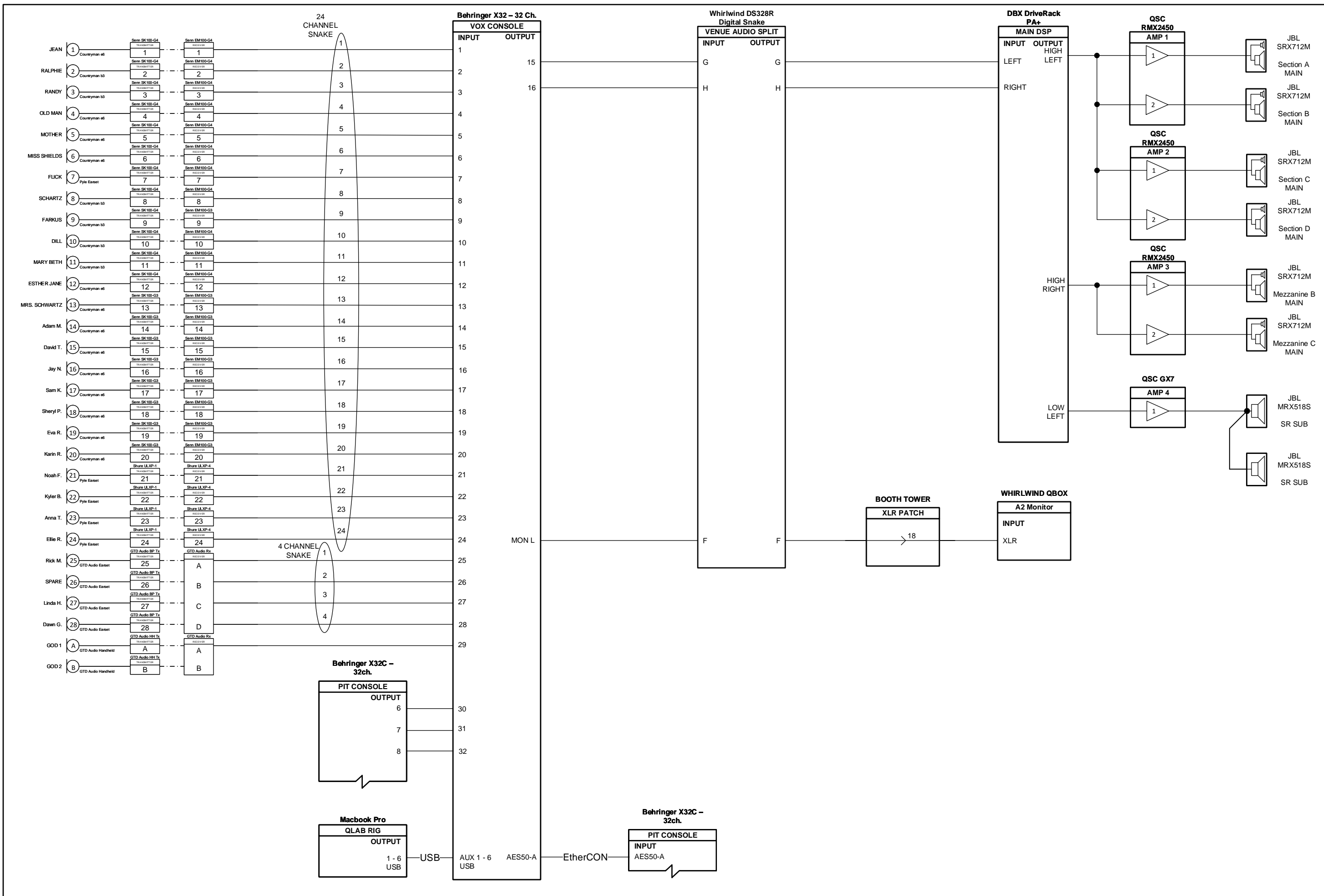

| Channel | Input | Processor | Output |
|---------|-------------------------------|-----------------|--------|
| 1 | JEAN (Countryman e6) | Senn SK100-G4 | 1 |
| 2 | RALPHIE (Countryman e8) | Senn SK100-G4 | 2 |
| 3 | RANDY (Countryman e8) | Senn SK100-G4 | 3 |
| 4 | OLD MAN (Countryman e6) | Senn SK100-G4 | 4 |
| 5 | MOTHER (Countryman e6) | Senn SK100-G4 | 5 |
| 6 | MISS SHIELDS (Countryman e6) | Senn SK100-G4 | 6 |
| 7 | FUCK (Pyle Easet) | Senn SK100-G4 | 7 |
| 8 | SCHARTZ (Countryman e8) | Senn SK100-G4 | 8 |
| 9 | FARKUS (Countryman e8) | Senn SK100-G4 | 9 |
| 10 | DILL (Countryman e8) | Senn SK100-G4 | 10 |
| 11 | MARY BETH (Countryman e8) | Senn SK100-G4 | 11 |
| 12 | ESTHER JANE (Countryman e6) | Senn SK100-G4 | 12 |
| 13 | MRS. SCHWARTZ (Countryman e6) | Senn SK100-G3 | 13 |
| 14 | Adam M. (Countryman e6) | Senn SK100-G3 | 14 |
| 15 | David T. (Countryman e6) | Senn SK100-G3 | 15 |
| 16 | Jay N. (Countryman e6) | Senn SK100-G3 | 16 |
| 17 | Sam K. (Countryman e6) | Senn SK100-G3 | 17 |
| 18 | Sheryl P. (Countryman e6) | Senn SK100-G3 | 18 |
| 19 | Eva R. (Countryman e6) | Senn SK100-G3 | 19 |
| 20 | Karin R. (Countryman e6) | Senn SK100-G3 | 20 |
| 21 | Noah F. (Pyle Easet) | Shure ULXP-1 | 21 |
| 22 | Kyler B. (Pyle Easet) | Shure ULXP-1 | 22 |
| 23 | Anna T. (Pyle Easet) | Shure ULXP-1 | 23 |
| 24 | Ellie R. (Pyle Easet) | Shure ULXP-1 | 24 |
| 25 | Rick M. (GTD Audio Easet) | GTD Audio BP Tx | A |
| 26 | SPARE (GTD Audio Easet) | GTD Audio BP Tx | B |
| 27 | Linda H. (GTD Audio Easet) | GTD Audio BP Tx | C |
| 28 | Dawn G. (GTD Audio Easet) | GTD Audio BP Tx | D |
| A | GOD 1 (GTD Audio Handheld) | GTD Audio HM Tx | A |
| B | GOD 2 (GTD Audio Handheld) | GTD Audio HM Tx | B |

"A Christmas Story"

The Stage at Island Park

Fargo-Moorhead Community Theatre

December, 2018

DIRECTOR:
LORI BARTLETT KOENIG

SOUND DESIGN:
CHRISTIAN EKREN

SOUND TECHNICIANS:
ELIANA R. MICHAELA D. LIAM F.

PIT ONE LINE

DATES:

LOAD-IN & TECH REHEARSALS:
NOVEMBER 26 – DECEMBER 6, 2018

PERFORMANCES:
DECEMBER 7-9, 13-16, 20-22, 2018

REVISION: 2

1st LOOK:
10/9/2018

FINAL COPY:
1/12/2019

DRAWN BY:
C. EKREN

DATE:
1/12/2019

SCALE:
NO SCALE

PLATE #:

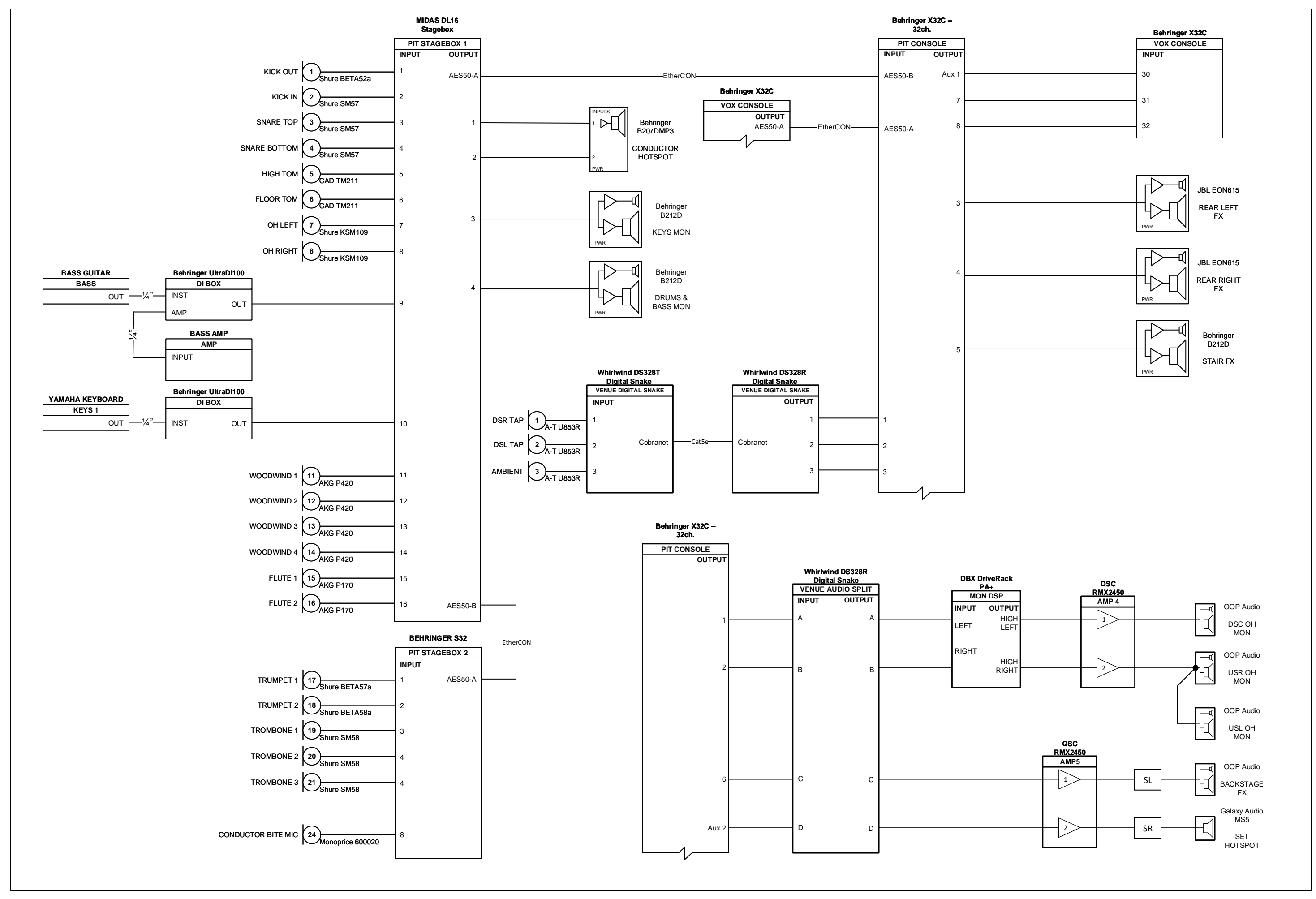

Vocal Patch - X32 - 1/12/2019

| DSP INPUT | PATCH | INPUT | SOURCE | DESCRIPTION | MIC |
|-----------|-------|-------|-------------------|---------------|---------------------|
| 1 | LOCAL | 1 | SENN G4 - 1 | Keith S. | SENN Countryman e6 |
| 2 | LOCAL | 2 | SENN G4 - 2 | Seth L. | SENN Countryman b3 |
| 3 | LOCAL | 3 | SENN G4 - 3 | Roman I. | SENN Countryman b3 |
| 4 | LOCAL | 4 | SENN G4 - 4 | Clayton P. | SENN Countryman e6 |
| 5 | LOCAL | 5 | SENN G4 - 5 | Shanna F. | SENN Countryman e6 |
| 6 | LOCAL | 6 | SENN G4 - 6 | Jeanie S. | SENN Countryman e6 |
| 7 | LOCAL | 7 | SENN G4 - 7 | Fi K. | SENN Pyle Earset |
| 8 | LOCAL | 8 | SENN G4 - 8 | Leif C. | SENN Countryman b3 |
| 9 | LOCAL | 9 | SENN G4 - 9 | Tyler H. | SENN Countryman b3 |
| 10 | LOCAL | 10 | SENN G4 - 10 | Asha F. | SENN Countryman b3 |
| 11 | LOCAL | 11 | SENN G4 - 11 | Josie K. | SENN Countryman b3 |
| 12 | LOCAL | 12 | SENN G4 - 12 | Ava G. | SENN Countryman e6 |
| 13 | LOCAL | 13 | SENN G3 - 13 | Kellie P. | SENN Countryman e6 |
| 14 | LOCAL | 14 | SENN G3 - 14 | Adam M. | SENN Countryman e6 |
| 15 | LOCAL | 15 | SENN G3 - 15 | David T. | SENN Countryman e6 |
| 16 | LOCAL | 16 | SENN G3 - 16 | Jay N. | SENN Countryman e6 |
| 17 | LOCAL | 17 | - | - | - |
| 18 | LOCAL | 18 | SENN G3 - 18 | Sheryl P. | SENN Countryman e6 |
| 19 | LOCAL | 19 | SENN G3 - 19 | Eva R. | SENN Countryman e6 |
| 20 | LOCAL | 20 | SENN G3 - 20 | Karin R. | SENN Countryman e6 |
| 21 | LOCAL | 21 | SHURE ULX-P - 21 | Noah F. | SHURE Pyle Earset |
| 22 | LOCAL | 22 | SHURE ULX-P - 22 | Kyler B. | SHURE Pyle Earset |
| 23 | LOCAL | 23 | SHURE ULX-P - 23 | Anna T. | SHURE Pyle Earset |
| 24 | LOCAL | 24 | SHURE ULX-P - 24 | Ellie R. | SHURE Pyle Earset |
| 25 | LOCAL | 25 | GTD Audio - 25 | Rick M. | GTD Earset |
| 26 | LOCAL | 26 | SENN G3 - 26 | Sam K. | SENN Countryman e6 |
| 27 | LOCAL | 27 | GTD Audio - 27 | Linda H. | GTD Earset |
| 28 | LOCAL | 28 | GTD Audio - 28 | Dawn G. | GTD Earset |
| 29 | LOCAL | 29 | GTD Audio - 29-30 | GOD MICS | GTD HH x2 (SUM OUT) |
| 30 | LOCAL | 30 | X32C PIT - OUT 6 | CONDUCTOR GOD | |
| 31 | LOCAL | 31 | X32C PIT - OUT 7 | TAP IN | |
| 32 | LOCAL | 32 | X32C PIT - OUT 8 | PIT IN | |
| AUX 1 | USB | 1 | QLAB - 1 | Qlab - MAIN L | |
| AUX 2 | USB | 2 | QLAB - 2 | Qlab - OH | |
| AUX 3 | USB | 3 | QLAB - 3 | Qlab Rear L | |
| AUX 4 | USB | 4 | QLAB - 4 | Qlab Rear R | |
| AUX 5 | USB | 5 | QLAB - 5 | Qlab SFX 1 | |
| AUX 6 | USB | 6 | QLAB - 6 | Qlab SFX 2 | |

| OUTPUT | PATCH | SOURCE | DESCRIPTION |
|--------|---------|---------|--------------------|
| 1 | LOCAL | | |
| 2 | LOCAL | | |
| 3 | LOCAL | | |
| 4 | LOCAL | | |
| 5 | LOCAL | | |
| 6 | LOCAL | | |
| 7 | LOCAL | | |
| 8 | LOCAL | | |
| 9 | LOCAL | | |
| 10 | LOCAL | | |
| 11 | LOCAL | | |
| 12 | LOCAL | | |
| 13 | LOCAL | | |
| 14 | LOCAL | | |
| 15 | LOCAL | MAIN L | Delays (B & C MEZ) |
| 16 | LOCAL | MAIN R | Mains (A, B, C, D) |
| Aux 1 | AES50-A | AUX 1 | VOX MON OUT |
| Aux 2 | AES50-A | AUX 2 | OH Mons (US) |
| Aux 3 | AES50-A | AUX 3 | REAR LEFT FX |
| Aux 4 | AES50-A | AUX 4 | REAR RIGHT FX |
| Aux 5 | AES50-A | AUX 5 | SFX 1 |
| Aux 6 | AES50-A | AUX 6 | SFX 2 |
| MON L | LOCAL | PFL BUS | A2 MON |

| DSP INPUT | PATCH | PHYSICAL INPUT | DESCRIPTION | MIC |
|-----------|------------|----------------|--------------------|---------------|
| 1 | AES50-B1 | DL16 - 1 | Kick OUT | Shure BETA52a |
| 2 | AES50-B2 | DL16 - 2 | Kick IN | Shure SM57 |
| 3 | AES50-B3 | DL16 - 3 | Snare TOP | Shure SM57 |
| 4 | AES50-B4 | DL16 - 4 | Snare BOTTOM | Shure SM57 |
| 5 | AES50-B5 | DL16 - 5 | Tom 1 | CAD TM411 |
| 6 | AES50-B6 | DL16 - 6 | FI Tom | CAD TM411 |
| 7 | AES50-B7 | DL16 - 7 | OH L | Shure KSM109 |
| 8 | AES50-B8 | DL16 - 8 | OH R | Shure KSM109 |
| 9 | AES50-B9 | DL16 - 9 | Bass | DI Box |
| 10 | AES50-B10 | DL16 - 10 | Keys 1 | DI Box |
| 11 | AES50-B11 | DL16 - 11 | WW 1 | AKG P420 |
| 12 | AES50-B12 | DL16 - 12 | WW 2 | AKG P420 |
| 13 | AES50-B13 | DL16 - 13 | WW 3 | AKG P420 |
| 14 | AES50-B14 | DL16 - 14 | WW 4 | AKG P420 |
| 15 | AES50-B15 | DL16 - 15 | Flute 1 | AKG P170 |
| 16 | AES50-B16 | DL16 - 16 | Flute 2 | AKG P170 |
| 17 | AES50-B17 | S32 - 1 | Trumpet 1 | Shure BETA57a |
| 18 | AES50-B18 | S32 - 2 | Trumpet 2 | Shure BETA58a |
| 19 | AES50-B19 | S32 - 3 | Trombone 1 | Shure SM58 |
| 20 | AES50-B20 | S32 - 4 | Trombone 2 | Shure SM58 |
| 21 | AES50-B21 | S32 - 5 | Trombone 3 | Shure SM58 |
| 22 | AES50-B22 | S32 - 6 | | |
| 23 | AES50-B23 | S32 - 7 | | |
| 24 | AES50-B24 | S32 - 8 | Conductor Bite Mic | Monoprice HH |
| 25 | LOCAL IN 1 | OH 1 | Ambient Feed | AT853-R |
| 26 | LOCAL IN 2 | OH 2 | Tap L | AT853-R |
| 27 | LOCAL IN 3 | OH 3 | Tap R | AT853-R |
| 28 | LOCAL IN 4 | | | |
| 29 | LOCAL IN 5 | | | |
| 30 | LOCAL IN 6 | | | |
| 31 | LOCAL IN 7 | | | |
| 32 | LOCAL IN 8 | | | |
| Aux IN 1 | AES50-A | X32 VOX AUX 1 | VOX MON IN | |
| Aux IN 2 | AES50-A | X32 VOX MTX 1 | OH Mons | |
| Aux IN 3 | AES50-A | X32 VOX MTX 3 | REAR LEFT FX | |
| Aux IN 4 | AES50-A | X32 VOX MTX 4 | REAR RIGHT FX | |
| Aux IN 5 | AES50-A | X32 VOX MTX 5 | SFX 1 | |
| Aux IN 6 | AES50-A | X32 VOX MTX 6 | SFX 2 | |

| OUTPUT | PATCH | PHYSICAL OUTPUT | SOURCE | DESCRIPTION |
|--------|----------|------------------|--------|-----------------|
| 1 | LOCAL | PIT X32C - OUT 1 | Aux 1 | OH MONITOR |
| 2 | LOCAL | PIT X32C - OUT 2 | Aux 1 | OH MONITOR |
| 3 | LOCAL | PIT X32C - OUT 3 | Aux 3 | REAR LEFT FX |
| 4 | LOCAL | PIT X32C - OUT 4 | Aux 4 | REAR RIGHT FX |
| 5 | LOCAL | PIT X32C - OUT 5 | Aux 5 | SL FX |
| 6 | LOCAL | PIT X32C - OUT 6 | Aux 6 | SR FX |
| 7 | LOCAL | PIT X32C - OUT 7 | D.O. | BITE MIC |
| 8 | LOCAL | PIT X32C - OUT 8 | MAIN C | MAIN OUTPUT |
| 9 | AES50-B1 | DL16 - OUT 1 | AUX 9 | COND HOTSPOT |
| 10 | AES50-B2 | DL16 - OUT 2 | AUX 10 | KEYS WEDGE |
| 11 | AES50-B3 | DL16 - OUT 3 | AUX 11 | DRUM/BASS WEDGE |
| 12 | AES50-B4 | DL16 - OUT 4 | D.O. | AMBIENT MIC |
| 13 | AES50-B5 | DL16 - OUT 5 | | |
| 14 | AES50-B6 | DL16 - OUT 6 | | |
| 15 | AES50-B7 | DL16 - OUT 7 | | |
| 16 | AES50-B8 | DL16 - OUT 8 | | |

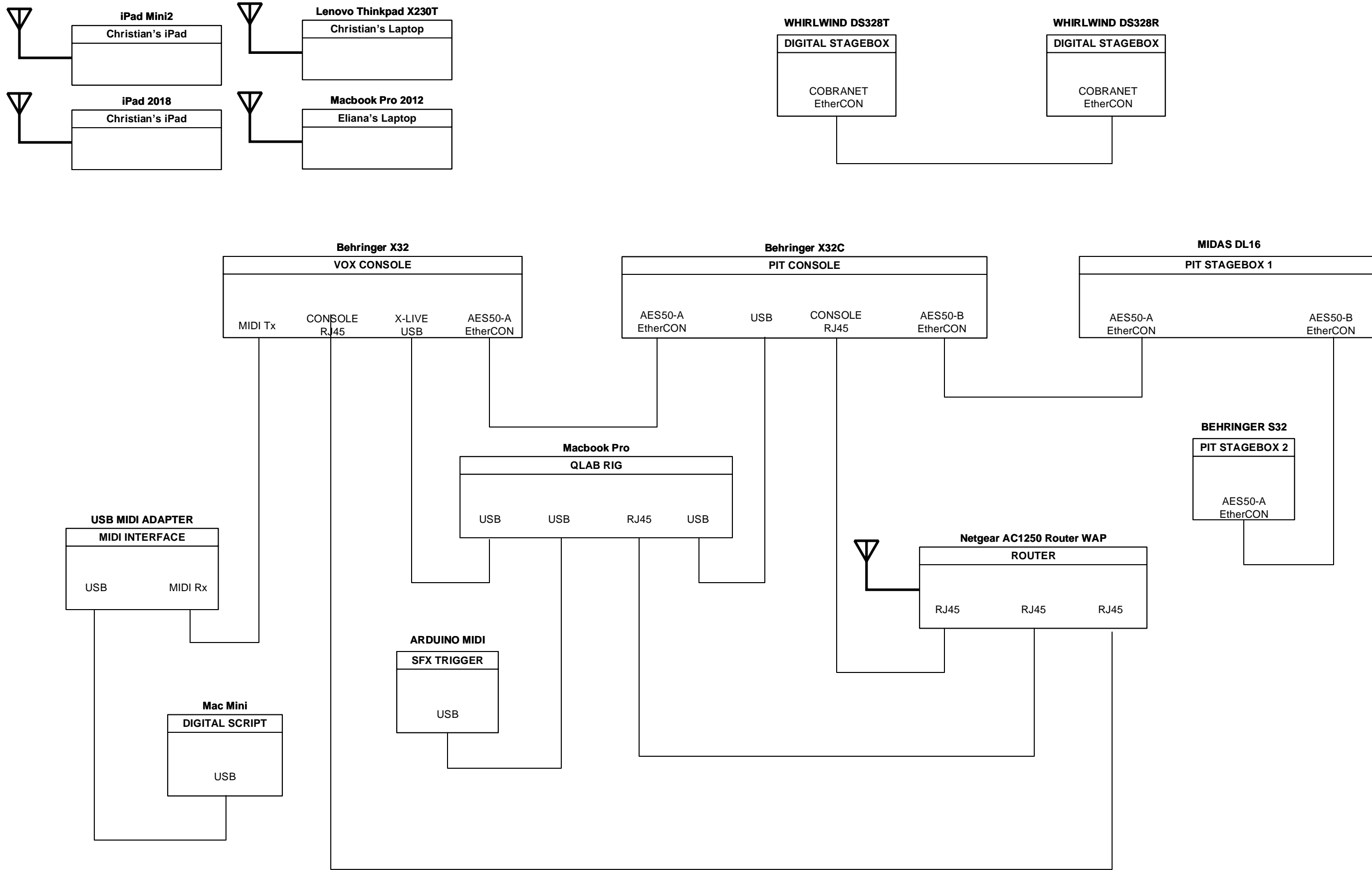

“A Christmas Story”
The Stage at Island Park
Fargo-Moorhead Community Theatre
 December, 2018

DIRECTOR:
 LORI BARTLETT KOENIG
SOUND DESIGN:
 CHRISTIAN EKREN
SOUND TECHNICIANS:
 ELIANA R. MICHAELA D. LIAM F.

CONTROL DIAGRAM

DATES:
LOAD-IN & TECH REHEARSALS:
 NOVEMBER 26 – DECEMBER 6, 2018
PERFORMANCES:
 DECEMBER 7-9, 13-16, 20-22, 2018

REVISION: 2
1st LOOK:
 10/9/2018
FINAL COPY:
 1/12/2019

DRAWN BY:
 C. EKREN
DATE:
 1/12/2019
SCALE:
 NO SCALE

PLATE #:
5 of 13

"A Christmas Story"

The Stage at Island Park

Fargo-Moorhead Community Theatre

December, 2018

DIRECTOR:
LORI BARTLETT
KOENIG

SOUND DESIGN:
CHRISTIAN EKREN

SOUND TECHNICIANS:
ELIANA R.
MICHAELA D.
LIAM F.

GROUND PLAN

DATES:

LOAD-IN & TECH REHEARSALS:
NOVEMBER 26 –
DECEMBER 6, 2018

PERFORMANCES:
DECEMBER 7-9, 13-
16, 20-22, 2018

REVISION: 2

1st LOOK:
10/9/2018

FINAL COPY:
1/12/2019

DRAWN BY:
C. EKREN

DATE:
1/12/2019

SCALE:
NO SCALE

PLATE #:

6 of 13

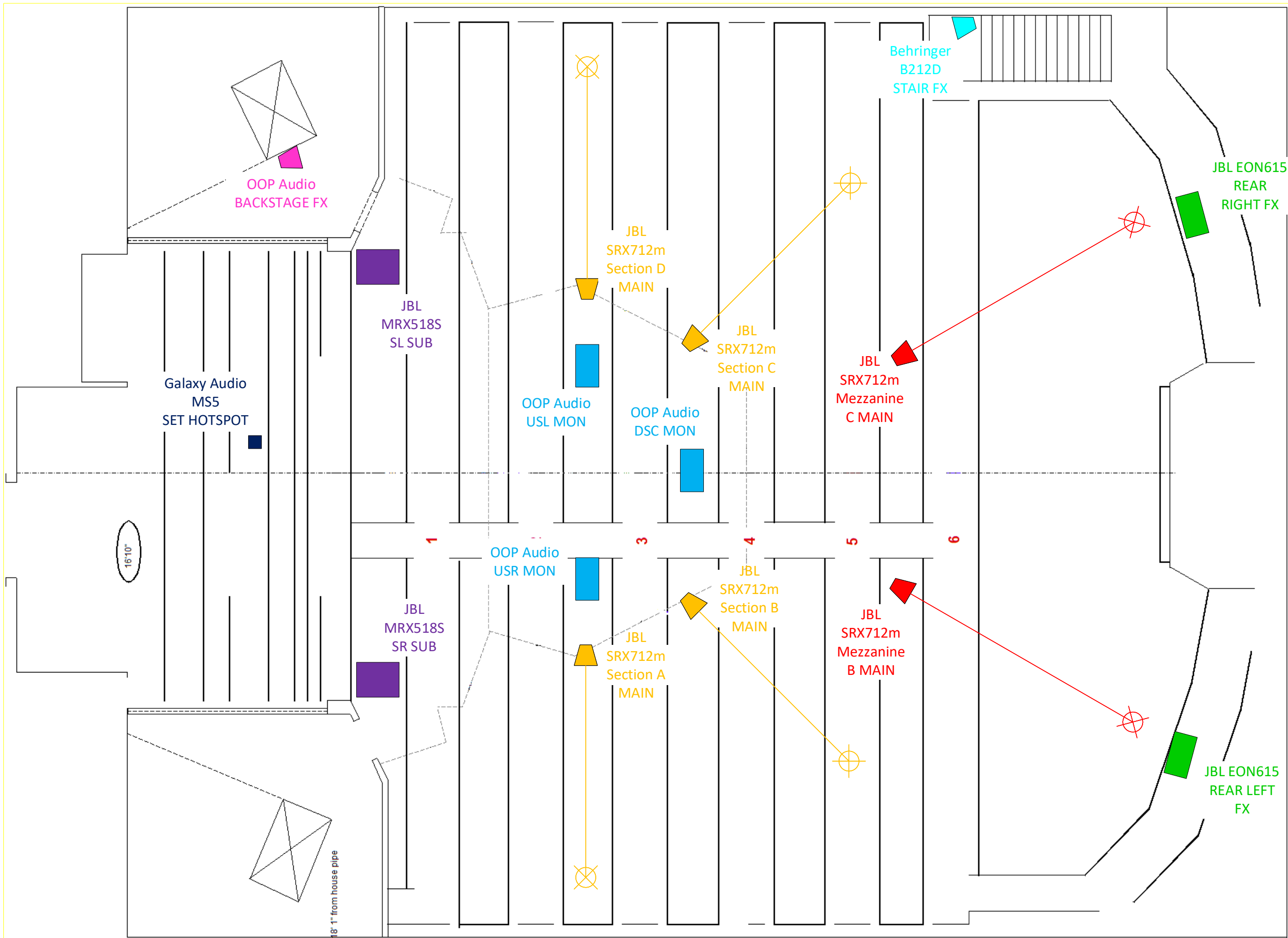

"A Christmas Story"

The Stage at Island Park

Fargo-Moorhead Community Theatre

December, 2018

DIRECTOR:
LORI BARTLETT KOENIG

SOUND DESIGN:
CHRISTIAN EKREN

SOUND TECHNICIANS:
ELIANA R. MICHAELA D. LIAM F.

WX DISTRIBUTION DIAGRAM

DATES:

LOAD-IN & TECH REHEARSALS:
NOVEMBER 26 – DECEMBER 6, 2018

PERFORMANCES:
DECEMBER 7-9, 13-16, 20-22, 2018

REVISION: 2

1st LOOK:
10/9/2018

FINAL COPY:
1/12/2019

DRAWN BY:
C. EKREN

DATE:
1/12/2019

SCALE:
NO SCALE

PLATE #:

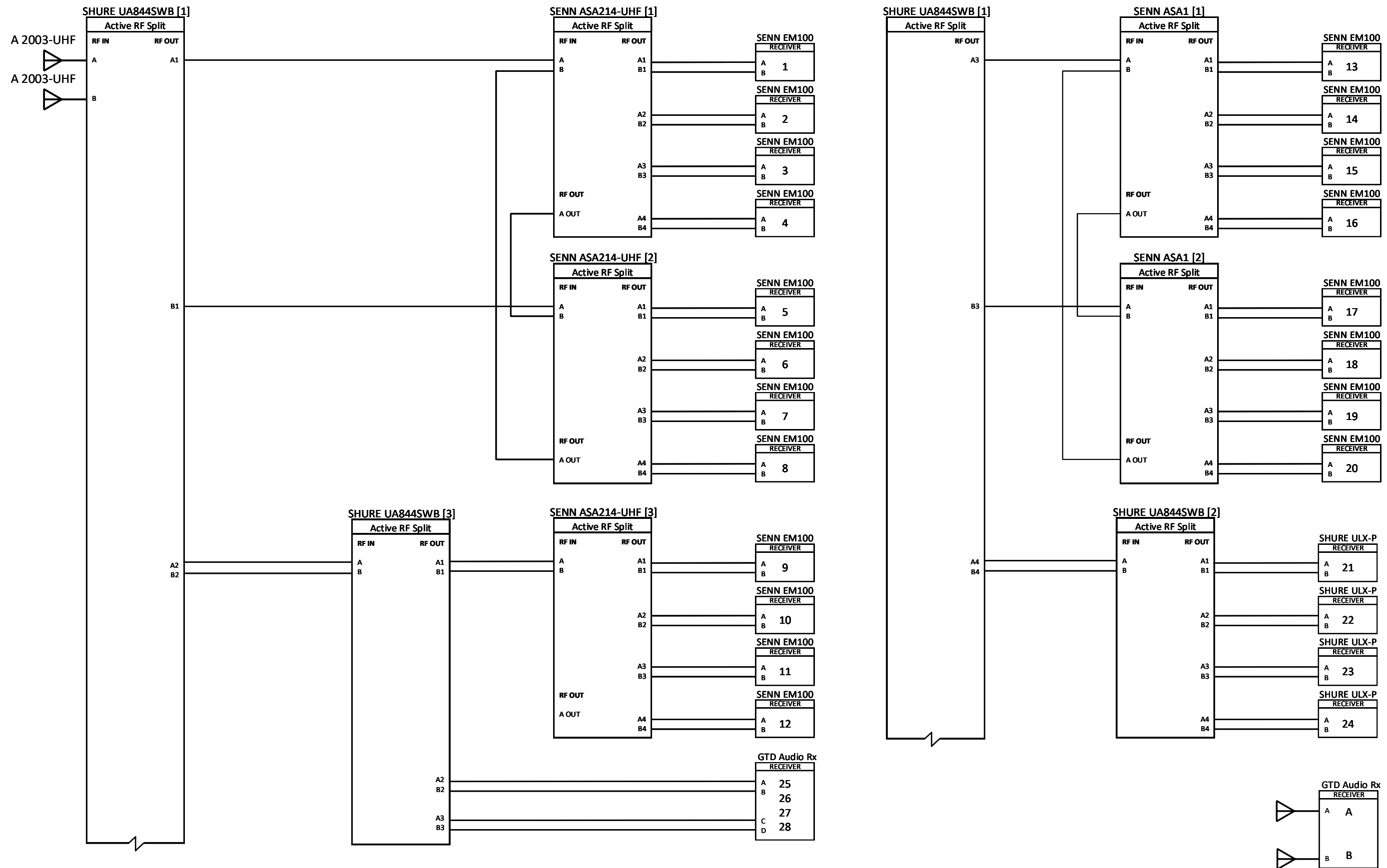

Wireless Assignments - 1/12/2019

| Wx # | Wx Model | Mic Type | Frequency | Actor | CHARACTER |
|------|------------------|--------------------|-----------|------------|------------------------|
| 1 | SENN G4 - 1 | SENN Countryman e6 | G | Keith S. | Jean Shepherd |
| 2 | SENN G4 - 2 | SENN Countryman b3 | G | Seth L. | Ralphie |
| 3 | SENN G4 - 3 | SENN Countryman b3 | G | Roman I. | Randy |
| 4 | SENN G4 - 4 | SENN Countryman e6 | G | Clayton P. | The Old Man |
| 5 | SENN G4 - 5 | SENN Countryman e6 | G | Shanna F. | Mother |
| 6 | SENN G4 - 6 | SENN Countryman e6 | G | Jeanie S. | Miss Shields |
| 7 | SENN G4 - 7 | SENN Pyle Earset | G | Fi K. | Flick |
| 8 | SENN G4 - 8 | SENN Countryman b3 | G | Leif C. | Schwartz |
| 9 | SENN G4 - 9 | SENN Countryman b3 | A | Tyler H. | Farkus |
| 10 | SENN G4 - 10 | SENN Countryman b3 | A | Asha F. | Dill |
| 11 | SENN G4 - 11 | SENN Countryman b3 | A | Josie K. | Mary Beth |
| 12 | SENN G4 - 12 | SENN Countryman e6 | A | Ava G. | Esther Jane |
| 13 | SENN G3 - 13 | SENN Countryman e6 | A | Kellie P. | Mrs. Schwartz |
| 14 | SENN G3 - 14 | SENN Countryman e6 | A | Adam M. | |
| 15 | SENN G3 - 15 | SENN Countryman e6 | A | David T. | |
| 16 | SENN G3 - 16 | SENN Countryman e6 | A | Jay N. | |
| 17 | SENN G3 - 26 | SENN Countryman e6 | A | Sam K. | Santa/Father |
| 18 | SENN G3 - 18 | SENN Countryman e6 | A | Sheryl P. | |
| 19 | SENN G3 - 19 | SENN Countryman e6 | A | Eva R. | |
| 20 | SENN G3 - 20 | SENN Countryman e6 | A | Karin R. | |
| 21 | SHURE ULX-P - 21 | SHURE Pyle Earset | J1 | Noah F. | |
| 22 | SHURE ULX-P - 22 | SHURE Pyle Earset | J1 | Kyler B. | |
| 23 | SHURE ULX-P - 23 | SHURE Pyle Earset | J1 | Anna T. | |
| 24 | SHURE ULX-P - 24 | SHURE Pyle Earset | J1 | Ellie R. | |
| 25 | GTD Audio - 25 | GTD Earset | ~B | Rick M. | |
| 26 | SENN G3 - 26 | GTD Earset | ~B | | |
| 27 | GTD Audio - 27 | GTD Earset | ~B | Linda H. | Diane/Chief Female Elf |
| 28 | GTD Audio - 28 | GTD Earset | ~B | Dawn G. | Maude/Nurse |

| Model | Total Inventory | In Use | Spare Inventory | # Broken | Notes: |
|--------------------|-----------------|--------|-----------------|----------|--------------------------------|
| e6 Earsets | 15 | 13 | 0 | 2 | 2 Broken before show (Poppins) |
| SENN e6 cables | 21 | 13 | 5 | 3 | 1 Broken before show (Poppins) |
| SENN b3 lavs | 7 | 6 | -1 | 2 | 1 connector repaired |
| SENN Pyle Earsets | 6 | 1 | 4 | 1 | |
| SHURE Pyle Earsets | 11 | 4 | 4 | 3 | |
| SHURE WL93 lavs | 4 | 0 | 4 | 0 | |
| GTD Earset | 7 | 4 | 2 | 1 | |

| Inventory Model | In-Use: |
|--------------------|---------|
| SENN G4 | 12 |
| SENN G3 | 8 |
| SHURE ULX-P | 4 |
| GTD Audio | 4 |
| | |
| SENN Countryman e6 | 13 |
| SENN Countryman b3 | 6 |
| SENN Pyle Earset | 1 |
| SHURE Pyle Earset | 4 |
| GTD Earset | 4 |
| SHURE WL93 | 0 |

INSTRUCTIONS: Update the RED columns as gear is broken, IF actors switch mic models (i.e. from e6 earset to a Pyle earset) please update column C (yellow)!

Be sure to type the model name EXACTLY right or the inventory tracking wont update correctly! (e.g. "ShUrE PyLe EaRset" vs "SHURE Pyle Earset")

"A Christmas Story"

The Stage at Island Park

Fargo-Moorhead Community Theatre

December, 2018

DIRECTOR:
LORI BARTLETT KOENIG

SOUND DESIGN:
CHRISTIAN EKREN

SOUND TECHNICIANS:
ELIANA R. MICHAELA D. LIAM F.

COMM GROUND PLAN - SHOW

DATES:

LOAD-IN & TECH REHEARSALS:
NOVEMBER 26 – DECEMBER 6, 2018

PERFORMANCES:
DECEMBER 7-9, 13-16, 20-22, 2018

REVISION: 2

1st LOOK:
10/9/2018

FINAL COPY:
1/12/2019

DRAWN BY:
C. EKREN

DATE:
1/12/2019

SCALE:
NO SCALE

PLATE #:

9 of 13

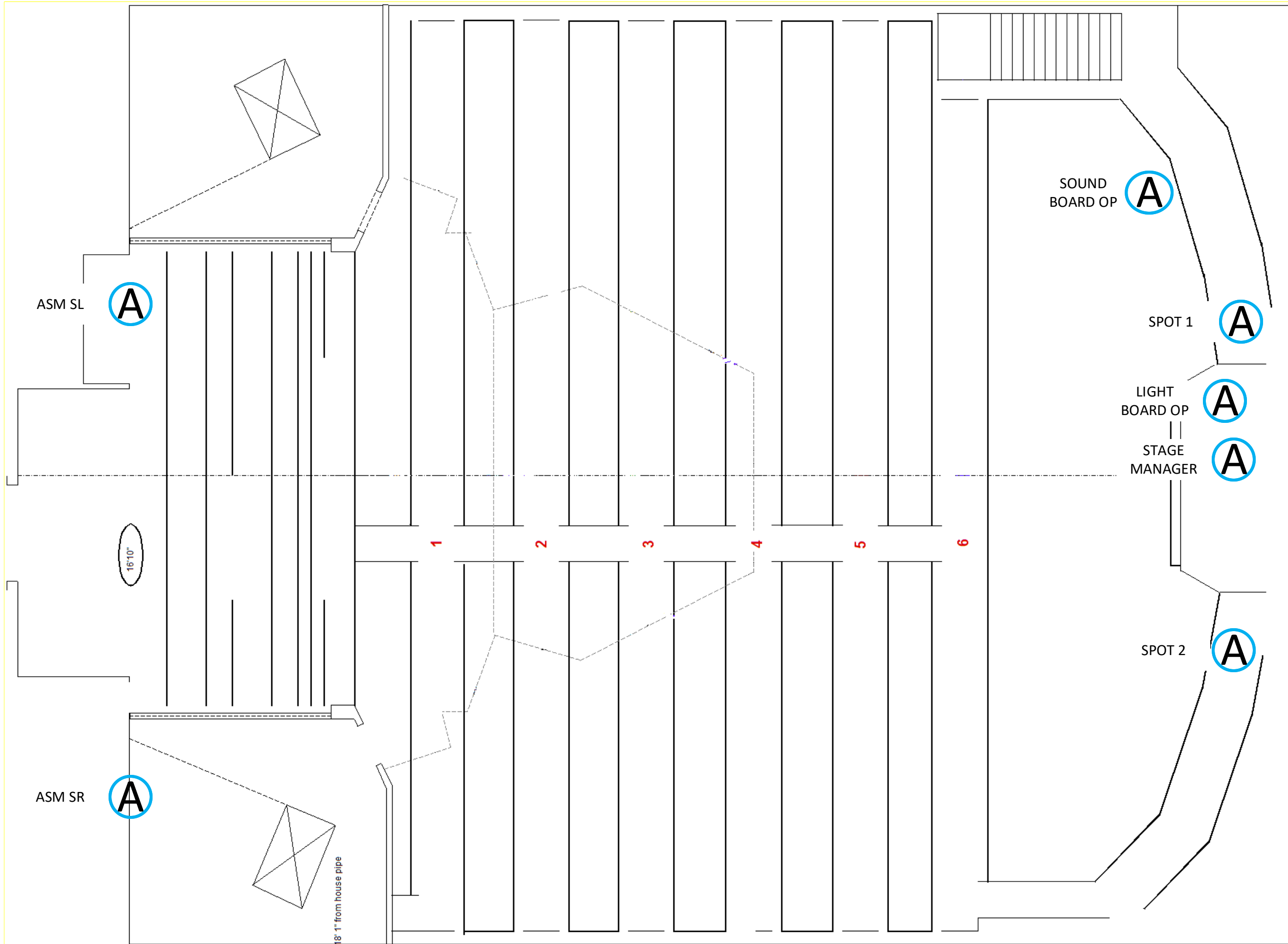

**"A Christmas
Story"**

**The Stage at
Island Park**

**Fargo-Moorhead
Community
Theatre**

December, 2018

DIRECTOR:
LORI BARTLETT
KOENIG

SOUND DESIGN:
CHRISTIAN EKREN

**SOUND
TECHNICIANS:**
ELIANA R.
MICHAELA D.
LIAM F.

VIDEO ONE LINE

DATES:

**LOAD-IN & TECH
REHEARSALS:**
NOVEMBER 26 –
DECEMBER 6, 2018

PERFORMANCES:
DECEMBER 7-9, 13-
16, 20-22, 2018

REVISION: 2

1st LOOK:
10/9/2018

FINAL COPY:
1/12/2019

DRAWN BY:
C. EKREN

DATE:
1/12/2019

SCALE:
NO SCALE

PLATE #:

10 of 13

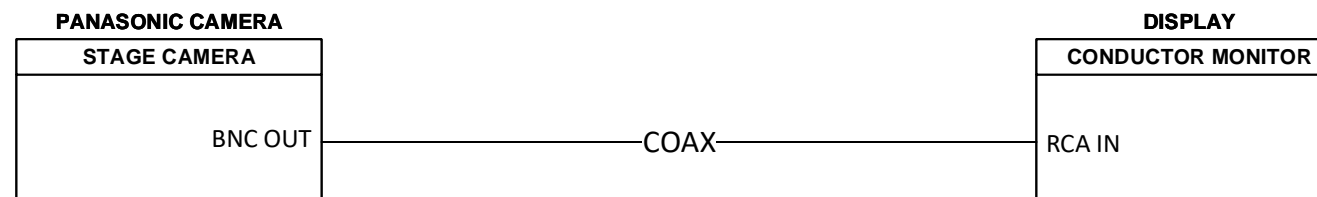
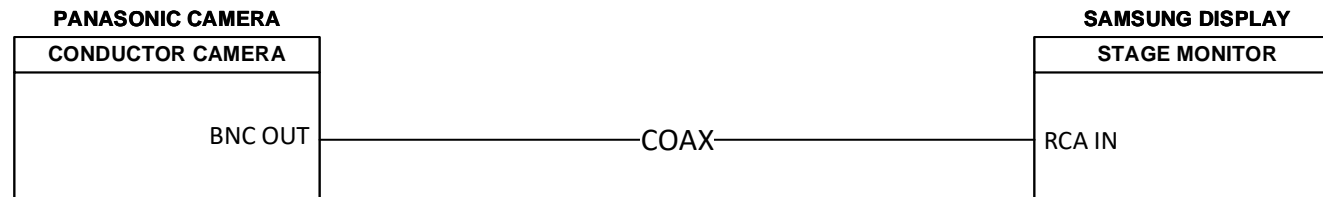

| CUE TYPE LEGEND | |
|-----------------------|--|
| LIVE/VOX SOUND EFFECT | |
| SPECIAL SOUND EFFECT | |
| RECORDED SOUND EFFECT | |

| CUE | PAGE | Description | Trigger |
|----------------|-------|--------------------------------------|---|
| Q201 | 20 | Car starts, offstage | MOTHER: "Frank! Start the car..." |
| Q206 | 20 | Bumpus Hounds | <i>Outside, sounds of the BUMPUS HOUNDS...</i> |
| Q219 | 21/22 | Car driving | <i>THE PARKERS are in the car...</i> |
| Q333 | 33 | Bumpus Hounds | <i>We then hear barking as...</i> |
| Q341 | 34 | Furnace explodes | <i>A loud boom is heard...</i> |
| FX355 | 35 | "ANGELIC" VOX VERB | ENSEMBLE "AHHHHH" |
| FX391** | 39 | FARKUS VERB | FARKUS & FILL: "Ha ha ha ha...." |
| Q425 | 42 | School bell | <i>School bell rings</i> |
| Q451 [ARM] | 44/45 | BB GUN IMPACTS | *REMOTE TRIGGER* |
| Q503 [DISARM] | | BB GUN | |
| Q515 | 51 | Bumpus Hounds | <i>The BUMPUS HOUNDS are heard offstage</i> |
| FX563 | 56 | DREAM VERB | <i>Another fanatasy...</i> |
| Q568 | 56 | Doorbell | <i>The Front doorbell rings</i> |
| Q581 | 58 | Doorbell | <i>The Front doorbell rings</i> |
| Q613 | 61 | Electrical zaps, pops, buzzes | <i>THE OLD MAN plugs the lamp in...</i> |
| Q672 | 67 | Bumpus Hounds | <i>Sounds of BUMPUS HOUNDS are heard</i> |
| Q685 | 68 | Car driving + starting? | <i>They get into the car...</i> |
| Q692 | 69 | Tire pops | <i>Sound of a punctured tire</i> |
| Q705.1 - 705.5 | 70 | Lug nuts hitting hubcap [INDIVIDUAL] | <i>Sounds of mimed lug nuts...</i> |
| Q709 | 70 | Lug nuts landing on ground, slow mo | <i>They freeze, except for their heads</i> |
| FX712 | 71 | SLOW MO VERB | RALPHIE: "Ohhhhhhh, fuddddgggeeee!" |
| Q796 | 79 | School bell | <i>The school bell rings</i> |
| Q821 | 82 | Firetruck siren | MISS SHIELDS: "Oh, my Loard!" |
| | 85 | FANTASY VERB | MISS SHIELDS: "Ha, ha, ha!" |
| Q951 | 95 | Bumpus Hounds (far away) | <i>Distant sounds of Bumpus Hounds..</i> |
| FX1042 | 104 | ECHO EFFECT FOR LINES | <i>Note: The following 8 lines...</i> |
| Q1065 | 106 | Crashing lamp sounds | <i>Suddenly, we hear crashing sounds</i> |
| Q1086 | 108 | Electrical zaps, pops, buzzes | <i>The outlet begins to smoke</i> |
| FX1226 | 122 | "ANGELIC" VOX VERB | ENSEMBLE "AHHHHH" |
| Q1238 [ARM] | 124 | BB GUN SFX + RICOCHET & IMPACT | *REMOTE TRIGGER* |
| Q1248 [DISARM] | 124 | Crunching sound + DISABLE BB GUN | <i>RALPHIE accidentally steps on his glasses...</i> |
| Q1259 | 126 | Bumpus Hounds | <i>Low barking..</i> |

| X32 CUE | CUE | DCA1 | DCA2 | DCA3 | DCA4 | DCA5 | DCA6 | DCA7 | DCA8 |
|---------|-------|--------------|----------------|------------------|------------------|-----------|------------------|-----------------|------------------|
| 0 | C175 | JEAN | MOTHER | RANDY | RALPHIE | OLD MAN | | | |
| 2 | C228 | KARIN R | ADAM M | | | | KIDS | MALE CHORUS | FEMALE CHORUS |
| 4 | C255 | JEAN | RALPHIE | MOTHER | OLD MAN | RANDY | WALLA | MALE CHORUS | FEMALE CHORUS |
| 6 | C274 | JEAN | RALPHIE | MOTHER | OLD MAN | RANDY | | MALE CHORUS | FEMALE CHORUS |
| 8 | C379 | JEAN | SCHWARTZ | FLICK | RALPHIE | RANDY | ESTHER JANE | | |
| 10 | C389 | JEAN | SCHWARTZ | FLICK | RALPHIE | FARKUS | DILL | ESTHER JANE | KIDS |
| 12 | C425 | MISS SHIELDS | RALPHIE | JEAN | KIDS | | | | |
| 14 | C452 | MISS SHIELDS | RALPHIE | ADAM | SAM | KIDS | KYLER | | 3 TOWNSWOMEN |
| 16 | C503 | MISS SHIELDS | RALPHIE | JEAN | | | | | |
| 18 | C512 | OLD MAN | JEAN | RALPHIE | MOTHER | RANDY | MISS SHIELDS | | |
| 20 | C619 | OLD MAN | ADAM | DAVID | SAM | RICK | MOTHER | TOWNSMEN | TOWNSWOMEN |
| 22 | C647 | OLD MAN | | | | | | TOWNSMEN | TOWNSWOMEN |
| 24 | C668 | JEAN | OLD MAN | MOTHER | RALPHIE | RANDY | | | |
| 26 | C723 | JEAN | MOTHER | RALPHIE | MRS. SCHWARTZ | SCHWARTZ | | TOWNSMEN | TOWNSWOMEN |
| 28 | C739 | OLDMAN | MOTHER + RANDY | RALPHIE | SAM K | RICK M | FARKUS | TOWNSMEN | TOWNSWOMEN |
| 30 | C771 | JEAN | SCHWARTZ | FLICK | RALPHIE | AVA | RANDY | GIRL 3 | MARY BETH |
| 32 | C805 | JEAN | MISS SHIELDS | SCHWARTZ | RALPHIE | MARY BETH | | BOYS | GIRLS |
| 34 | C818 | FLICK | MISS SHIELDS | KARIN | DAVID | DAWN | KIDS | MEN | WOMEN |
| 36 | C837 | JEAN | MISS SHIELDS | RALPHIE | | | | | |
| 38 | C854 | FARKUS | DILL | RALPHIE | SCHWARTZ | FLICK | MISS SHIELDS | BOYS | GIRL + RANDY |
| 40 | C893 | FARKUS | DILL | JEAN | RANDY | RALPHIE | SCHWARTZ | KYLER B | KIDS |
| 42 | C902 | MOTHER | DILL | JEAN | RANDY | RALPHIE | SCHWARTZ | KYLER B | KIDS |
| 44 | C918 | MOTHER | FLICK | MARY BETH | GIRL 1 | ANA T | SCHWARTZ | ESTHER JANE | KIDS |
| 46 | C927 | MOTHER | JEAN | RALPHIE | RANDY | OLD MAN | | | |
| 48 | C975 | SANTA | ELVES | FEMALE CHIEF ELF | MARY BETH | Ellie R. | | | |
| 50 | C1009 | SANTA | ELVES | NOAH | KID 1 | ANNA | RANDY | KID 3 | RALPHIE |
| 52 | C1019 | SANTA | ELVES | FEMALE CHIEF ELF | KIDS | KID 6 | JEAN | RANDY | RALPHIE |
| 54 | C1034 | SANTA | ELVES | JEAN | RANDY | JAY | FEMALE CHIEF ELF | | RALPHIE |
| 56 | C1049 | SANTA | MALE ELVES | FEMALE ELVES | FEMALE CHIEF ELF | | | | |
| 58 | C1059 | JEAN | OLD MAN | MOTHER | RANDY | RALPHIE | | | |
| 60 | C1138 | RANDY | RALPHIE | NOAH | KYLER | FLICK | ELLIE | SCHWARTZ + DILL | KIDS |
| 62 | C1163 | RANDY | RALPHIE | | OLD MAN | | | | KIDS |
| 64 | C1178 | RANDY | RALPHIE | MOTHER | OLD MAN | JEAN | | PRAIRIE MEN | PRAIRIE WOMEN |
| 66 | C1272 | RANDY | RALPHIE | MOTHER | OLD MAN | JEAN | WAITER | MEN | WOMEN (AND KIDS) |

INDICATES DCA FADER OUT ON CUE GO

INDICATES DCA FADER TO SPECIFIC LEVEL ON CUE GO

| Tx | Rx | Channel | Command | Value | Description |
|---------------|-----------------|----------------|----------------|--------------|---------------------------|
| BB GUN | MBP | 1 | Note | 1 | BB GUN TRIGGER |
| X32 | Mac Mini | 2 | Note | 2 | ESCAPE [END PRESENTATION] |
| X32 | Mac Mini | 2 | Note | 0 | LEFT [PREV PAGE] |
| X32 | Mac Mini | 2 | Note | 1 | RIGHT [NEXT PAGE] |
| X32 | MBP | 3 | Program Change | 0 | Qlab VOX [PANIC] |
| X32 | MBP | 3 | Program Change | 1 | Qlab VOX [PREV] |
| X32 | MBP | 3 | Program Change | 2 | Qlab VOX [NEXT] |
| X32 | MBP | 3 | Program Change | 3 | Qlab VOX [GO] |
| X32C | MBP | 4 | Program Change | 0 | Qlab PIT [PANIC] |
| X32C | MBP | 4 | Program Change | 1 | Qlab PIT [PREV] |
| X32C | MBP | 4 | Program Change | 2 | Qlab PIT [NEXT] |
| X32C | MBP | 4 | Program Change | 3 | Qlab PIT [GO] |

| MIDI Devices | Devices Names |
|---------------------|----------------------|
| Mac Mini | Man Mini |
| Macbook Pro | Macbook Pro |
| X32 | [X-LIVE] |
| X32C | [X-USB] |
| BB GUN | [MocoLUFA] |